

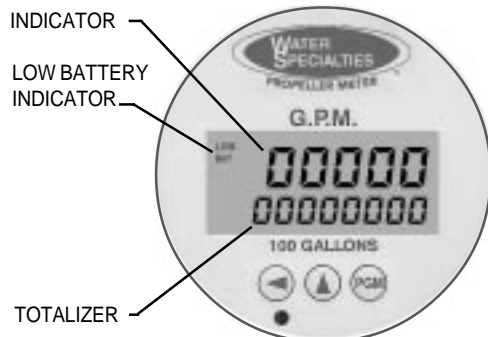

MODEL LP-22-D
 150 psi STRAP-ON SADDLE METER
 SOLID STATE ELECTRONIC PROPELLER METER
 CAST STRAP-ON SADDLE
 DIGITAL INDICATOR-TOTALIZER
 4" SIZE



TYPICAL
 DIGITAL INDICATOR-TOTALIZER



DESCRIPTION

MODEL LP-22-D STRAP-ON SADDLE METERS are designed for irrigation or other low pressure service up to 150 PSI working pressure. The strap-on design permits installation on many types of pipe material (3/16" PVC wall minimum). It is necessary upon ordering to furnish the I.D. dimension of the pipe the meter is to be mounted on, for calibration purposes. The pipe O.D. dimension must be 4.50" for proper sealing of the saddle to the pipe.

INSTALLATION is made by cutting a hole in the existing pipe line and then attaching the meter securely to the line. U-bolts or U-straps for attaching the meter saddle to the line are furnished with each meter. The meter can be installed horizontally, or inclined on suction or discharge lines. The meter must have a full flow of liquid for proper accuracy. Fully opened gate valves, fittings, or other obstructions that tend to set up flow disturbances should be a minimum of ten pipe diameters upstream and two pipe diameters downstream from the meter. Installations with less than ten pipe diameters of straight pipe require straightening vanes. Meters with straightening vanes require at least five pipe diameters upstream and two pipe diameters downstream. An optional kit of adapters with up to 100 feet of cable is available to locate the digital indicator-totalizer at remote locations.

PROPELLER is magnetically coupled with the electronic sensor through the sealed gearbox. This completely eliminates water entering the meter assembly, and eliminates all moving parts except for the propeller. The propeller is a conical shaped three bladed propeller, injection molded of thermoplastic material resistant to normal water corrosion and deformity due to high flow velocities.

BEARING in propeller is a water lubricated ceramic sleeve and spindle bearing system with a ceramic/stainless steel spindle. Dual ceramic thrust bearings, standard on all meters, handle flows in both forward and reverse directions. The bearing design promotes extended periods of maintenance free propeller operation. The bearing design promotes extended periods of maintenance free propeller operation.

DIGITAL INDICATOR-TOTALIZER has a non-volatile EEPROM memory to store totalizer count (updated every 60 minutes while running). The indicator dial can be furnished in GPM, CFS, MGD or any standard liquid measuring units with a choice of totalizer measuring units. The display is programmable to update from 0.5 to 5 seconds, and timeout from 1 to 9999 seconds.

INDICATOR (rate) FUNCTION is a five digit indicator with .35" tall numbers, programmable with 0 to 4 decimal point place with 0.0001 to 9999 rate scaling factor. The calculation method is 1/Tau; programmable smoothing of 0 to 99%; rate zero time of 8 seconds.

TOTALIZER FUNCTION is an eight digit totalizer with .20" tall numbers, programmable with 0 to 4 decimal places, and a total scaling factor of 0.0001 to 9999. The totalizer can be reset from the front panel or disabled permanently.

SPECIFICATIONS

ACCURACY	Plus or minus 2% of actual flow within the range specified for each meter size.
PRESSURE RANGE	Up to 150 PSI maximum working pressure.
TEMPERATURE RANGE	140° F Maximum. Consult factory for special construction for higher temperatures.
MINIMUM FLOWS	As shown for each meter size and construction are required for accurate registration. See flow chart.
MAXIMUM FLOWS	As shown for each meter size and construction are rated for continuous operation. See flow chart.
INTERMITTENT FLOWS	As shown for each meter size are rated for 10% to 15% of the total time the meter is operating. Consult factory for High Velocity construction when intermittent flows are higher than shown on flow chart and/or when longer operating periods are required.
MATERIALS	Used in construction are chosen to minimize the corrosive effects of the liquids measured by the meter assembly. MAGNETS - permanent ceramic type INTERIOR BEARINGS - factory lubricated PROPELLER BEARING - ceramic sleeve type PROPELLER SPINDLE - ceramic coated stainless steel PROPELLER - injection molded thermoplastic GEARBOX - cast bronze SEPARATOR - stainless steel SHAFTS AND BOLTS - stainless steel SADDLE - fusion epoxy coated ductile iron U-BOLTS - electro-galvanized dichromate sealed 101 B steel U-STRAPS - stainless steel
OPTIONAL EQUIPMENT	Remote mounting kit with up to 100 feet of cable, digital transmitter, and a wide range of controls and instruments for indicating, totalizing and recording flow data for each meter. Special constructions and materials are available upon request.
ORDERING INFO	Must be specified by the customer and includes: minimum and maximum flow ranges, pipe I.D., temperature of meter environment, indicator scale and units, totalizer dial units, type of materials and construction and optional equipment desired.

MODEL LP-22-D
 150 psi STRAP-ON SADDLE METER
 SOLID STATE ELECTRONIC METER
 CAST STRAP-ON SADDLE
 DIGITAL INDICATOR-TOTALIZER
 4" SIZE

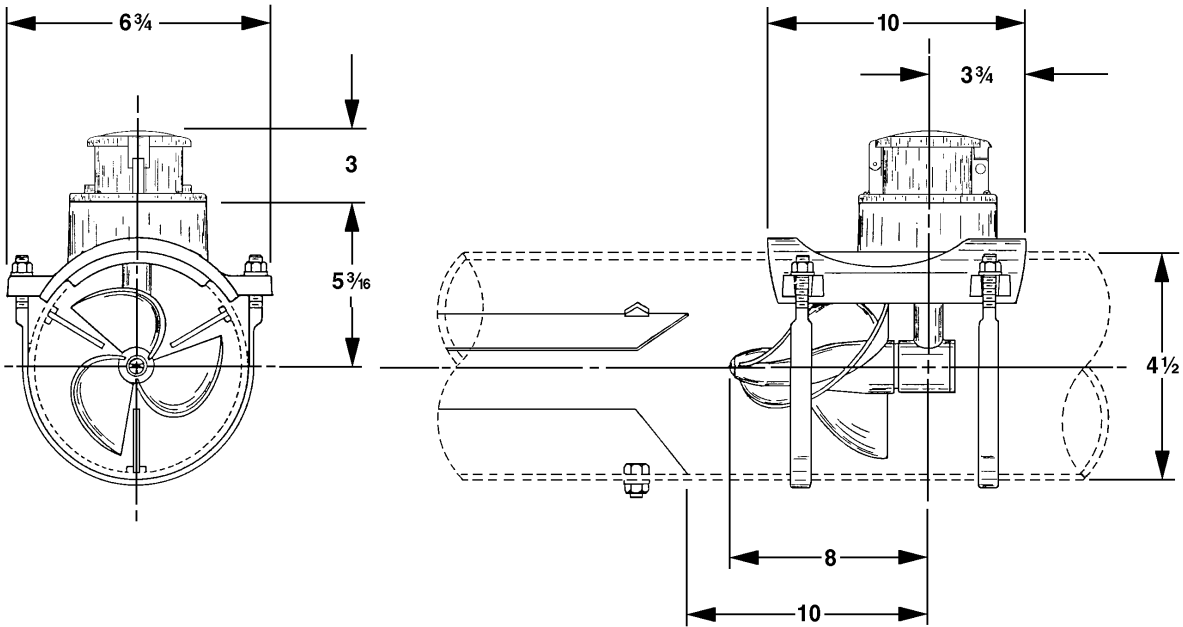

NOTE: PLEASE SPECIFY PIPE I.D.

METER & PIPE SIZE	FLOW RANGES, GPM			SHIPPING WEIGHT POUNDS
	MIN.	MAX.	INT.	
4	80	500	700	28



Visit our Website: www.mccrometer.com
 E-Mail: info@mccrometer.com

3255 WEST STETSON AVENUE • HEMET, CALIFORNIA 92545-7799 USA
 TEL: 909-652-6811 • FAX: 909-652-3078

Copyright © 2002 McCrometer. All printed material should not be changed or altered without permission of McCrometer. The published technical data and instructions are subject to change without notice. Contact your McCrometer representative for current technical data and instructions.